

CRYOSYSTEM CLASSIC SERIES

SET-UP AND TECHNICAL MANUAL



* Includes information on the Cryo-La, the Cryo-BAT and units not equipped with electronic options.

Custom
BioGenic
Systems

www.custombiogenics.com

150 Shafer Drive ♦ Romeo, MI 48065 ♦ USA

1.800.523.0072 ♦ Tel: 1.586.331.2600 ♦ Fax: 1.586.331.2588



Leading the World with Innovative Cryopreservation Technology Solutions

- IMPORTANT INFORMATION -

We at Custom Biogenic Systems are proud of our work, and appreciate your purchase of this product. With proper care, this equipment will be trouble free for many years to come. Before setting up and using your new cryogenic system, first check to see that all parts are accounted for and that no damage has occurred during shipping. Also, read this manual completely before proceeding to set-up. If at any time you are unsure of the procedures for set-up and use of this product, please contact Custom Biogenic Systems or your Custom Biogenic Systems representative.

- TESTING UNIT PRIOR TO USE -

Although every unit is factory tested it is recommended that dewars be tested again to ensure the viability and safety of stored media. Simply follow these steps before putting unit into service:

1. Unpack, open lid and remove foam plug
2. Fill unit to approximately 1/3 full (see fill instruction on page 7)
3. Replace foam plug and allow unit to stand for 24 hours
4. Measure the depth of the Liquid Nitrogen and make a note of this depth
5. Let unit stand another 24 hours
6. Measure the depth a second time and make a note of this depth
7. The depth should go down no more than approximately 1/4" in 24 hours.

During this initial testing watch for signs of excess frosting or sweating on the outside of the dewar. Also take note of excess liquid nitrogen boil off especially after the second weigh-in. Liquid Nitrogen should settle down (cease boiling) after an hour.

PRODUCT WARRANTY

Custom BioGenic Systems warrants all manufactured cryogenic equipment to be free from defects in workmanship and materials for a period of one year. Custom BioGenic Systems' liabilities under the warranty shall be limited to correcting or replacing the defective workmanship or materials. A claimant under the warranty must notify CustomBioGenic Systems within ten (10) days after discovery of the defect and immediately discontinue use of the defective equipment. Custom BioGenic Systems reserves the right, at their discretion, to correct the defect(s) in the field without return shipment to Romeo, Michigan. This warranty does not cover defects on cryogenic equipment resulting from abusive handling and subsequent failure.

Serial Number _____

Model number _____

For Technical Assistance Call: 1.800.523.0072 (U.S. Only)

Phone: 586.331.2600 Fax: 586.331.2588

www.custombiogenics.com

- TABLE OF CONTENTS -

SAFETY - PAGE 1

FRONT PANEL CONTROL IDENTIFICATION

LA-2B - PAGE 3

BAT-1B - PAGE 4

STAND ALONE SYSTEMS - PAGE 5

CONNECTION IDENTIFICATION

LA-2B - PAGE 3

BAT-1B BATTERY REPLACEMENT - PAGE 4

SET-UP AND OPERATION - PAGE 5

SENSOR PROBE ADJUSTMENT

LA-2B - PAGE 6

BAT-1B - PAGE 6 & 7

FILL INSTRUCTIONS - PAGE 7

UNIT PARAMETERS - PAGE 8

PARTS AND ACCESSORIES - PAGE 9 & 10

TROUBLESHOOTING - PAGE 11

- SAFETY -

IMPORTANT!

The following section on LIQUID NITROGEN SAFETY should be read carefully and followed completely, but is by no means a complete volume on the use of cryogenic liquids. All personnel should have a complete knowledge of the correct procedures, as well as the hazards of working with liquid nitrogen. Failure to do so could result in serious injury or death.

WARNING

LIQUEFIED GASES ARE EXTREMELY COLD LIQUIDS. LIQUID NITROGEN EXISTS AT -196°C. BECAUSE OF THESE TEMPERATURES, LIQUEFIED GASES WILL "BURN" IF THEY COME INTO CONTACT WITH SKIN. NEVER ALLOW DIRECT SKIN CONTACT WITH LIQUID NITROGEN OR SERIOUS BURNS WILL RESULT.

ALTHOUGH LIQUID NITROGEN ITSELF IS NON-TOXIC, WHEN RELEASED IN TO A CONFINED SPACE IT CAN DISPLACE OXYGEN CAUSING ASPHYXIATION. ENTERING AN OXYGEN DEFICIENT ROOM CAN CAUSE UNCONSCIOUSNESS WITHOUT WARNING. ALWAYS CHECK AIR QUALITY UPON ENTERING A ROOM WHERE CRYOGENIC LIQUIDS ARE BEING USED AND IF POSSIBLE, HAVE A RESPIRATOR AVAILABLE.

INTRODUCING EQUIPMENT WHICH IS AT ROOM TEMPERATURE INTO LIQUID NITROGEN IS ALWAYS SOMEWHAT HAZARDOUS. BEWARE OF SPLASHING AND "BOILING" WHICH MAY OCCUR. ALL PERSONNEL PERFORMING THESE OPERATIONS SHOULD BE FULLY INFORMED OF PROPER HANDLING PROCEDURES AND SHOULD ALWAYS WEAR A FACE SHIELD AND PROTECTIVE CLOTHING.

LIQUEFIED GASES SHOULD NEVER BE USED IN COMBINATION WITH OTHER SUBSTANCES WITHOUT KNOWING WHAT THE RESULT WILL BE. WHEN IN DOUBT, CONTACT A COMPETENT AUTHORITY.

- SAFETY -

HANDLING

Personnel handling liquefied gases should be thoroughly instructed as to the nature of these materials. Proper training is essential to safety and will ensure the accident-free use of this equipment.

Because of their low temperatures, liquefied gases will burn the skin much the same way as hot liquids can. For this reason, always wear the proper protective clothing when handling these materials. It is advised that during use, handlers of liquid nitrogen should protect themselves by wearing goggles or face shields, heavy rubber gloves large enough to allow quick removal and a heavy rubber apron. It is preferable that shoes worn at these times have high tops as to not permit accidentally spilled liquid from entering as well as pant legs which come down over the tops of shoes for further protection.

Also because of the extremely low temperatures, liquid nitrogen should only be handled and transported in approved containers. Many materials become brittle and may shatter when put into contact with liquid nitrogen and other cryogenic liquids.

FIRST AID

In the event a person is burned by liquefied gas, the following first aid treatment should be given while awaiting the arrival of medics or a doctor:

1. If the material has contacted skin or eyes, flood those areas with large quantities of unheated water and protect frozen areas with loose, bulky, dry and sterile dressings.
2. If the skin is blistered or there is a chance that the eyes have been affected, seek medical help immediately.

- BEFORE USE -

Caution: Do not plug in the AC power plug before completing initial set-up. Check to see that all parts are accounted for and are damage free.

- LA-2B CONTROLS & CONNECTIONS -

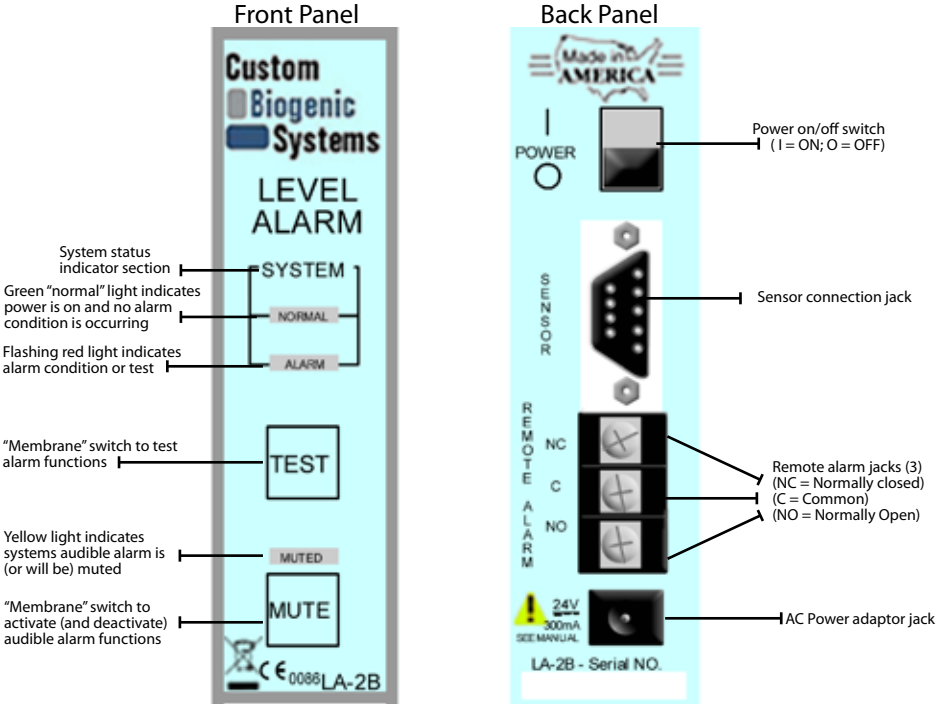

- LA-2B CONTROLS & CONNECTIONS -

Use the diagrams to ensure correct hook-up of all parts (drawings not to scale)

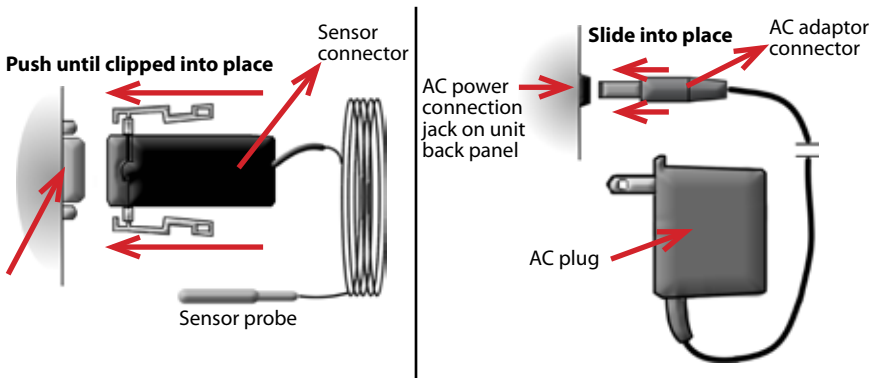

- BAT-1B CONTROLS & CONNECTIONS -

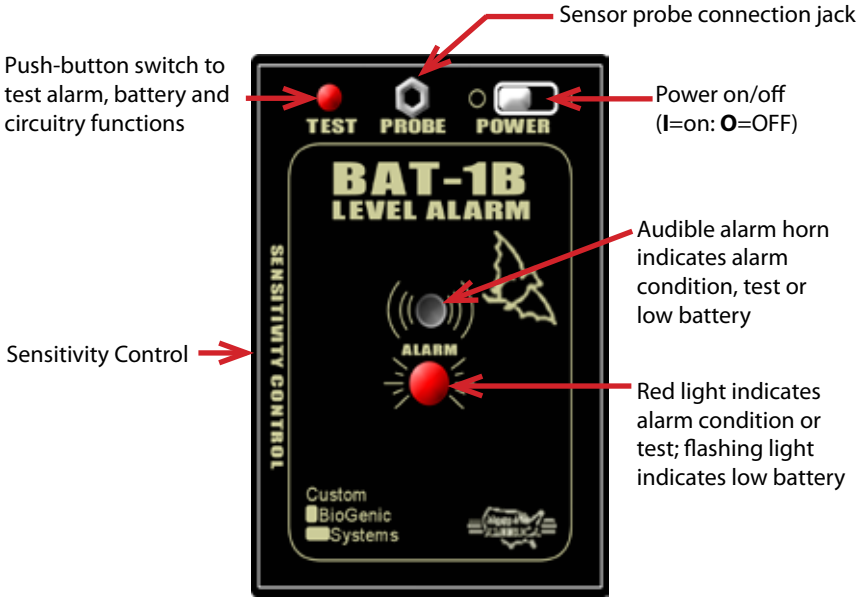

- POWER CONNECTIONS -

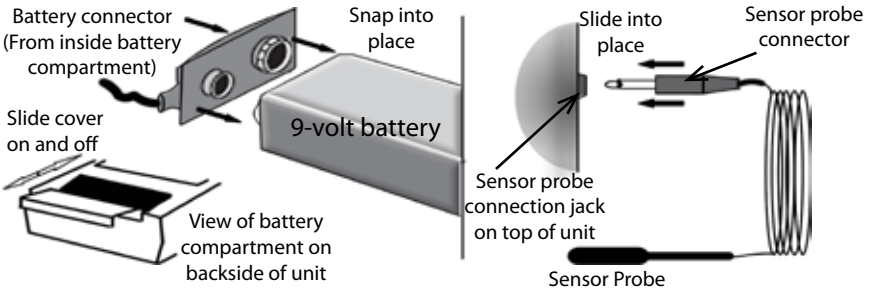

- SPECIFICATIONS -

Power requirements: One 9-volt battery
 Dimensions (L x W x H): 3 1/4" x 1 1/2" x 4 3/8" or
 8.3cm x 3.8cm x 11.1cm
 Weight: 7 oz. or 0.196kg (including battery)

- SET-UP AND OPERATION -

After following the test procedure outlined at the beginning of this manual, the unit is ready for set-up and operation. Use the following steps to properly set the unit up. Test daily to ensure proper operation.

LA-2B

1. Connect the 24 volt DC power plug to it's socket on the back panel
2. Then, if desired, connect a remote alarm using the socket provided below the power wire.
3. Sensor probe alarm level is pre-set at the factory to 5 inches on the 2002, 4002, and 6002 series. To change the pre-set level see the instructions on page 6.
4. At this point the unit can be filled with liquid nitrogen according to the fill instructions on page 7.
5. Finally, the unit can be plugged into an appropriate power source and powered up.
6. Push the TEST button to test the system integrity. Also test the MUTE switch and become familiar with the sound of the audible alarm.
7. Double check set-up including all connections to ensure accurate trouble free operation. Test daily to ensure proper operation.

BAT-1B

1. Sensor probe alarm level is pre-set at the factory to 5 inches on the 2002, 4002, and 6002 series. To change the pre-set level see the instruction on page 6.
2. At this point the unit can be filled with liquid nitrogen according to the fill instructions on page 7.
3. Move the power switch to the ON position to power the unit up.
4. Push TEST button to test the system integrity.
5. Double check set-up including all connections to ensure accurate trouble free operation. Test daily to ensure proper operation.

- STAND ALONE SYSTEMS -

The Stand Alone version of the Cryosystem Series has no electronic controls. These units can be easily upgraded to operate with either the CRYO-LA or the CRYO-BAT Level Alarms. For more information or to obtain the upgrade call Custom Biogenic Systems at 1-800-523-0072 or 1-586-331-2600 if calling from outside the continental U.S.

- SENSOR PROBE ADJUSTMENT -

This section describes how the sensor probe is adjusted to activate an alarm at a specified liquid level. The probe levels are pre-set at the factory at general locations (listed in the text below) that may or may not suit your particular needs. To change these pre-set levels or if replacing a defective probe, the following dimensions and diagrams will aid in accurate probe level settings.

If replacing a defective probe see figure B. on page 7 for the probe wire connector location.

The probe level measurement is based on the length of the probe wire **from the upper neck opening down to the end of the sensor probe itself** (as shown in figure A). At the factory pre-sets, the probe levels and corresponding wire lengths are as follows:

MODEL	Probe level measured from the bottom of the vessel	Probe wire length measured from the upper neck opening to the probe tip
Series 2002 -	5 inches	23 inches
Series 4002 -	5 inches	28 inches
Series 6002 -	5 inches	30 inches

To accurately change the probe levels simply mark the probe wire at the neck opening and either add or subtract wire from the known pre-set figures to achieve the new level location. For example: To change a Series 2002 pre-set level from 5 inches to 8 inches from the bottom, slide the probe wire 3 inches up from its current location. The probe will then be 8 inches from the bottom, and the wire length from the neck opening to the probe tip will no longer be 23 inches but it will be 20 inches, because 3 inches of wire have been pulled up.

This formula will work for all models and will also work when replacing the sensor probe.

FIGURE A.

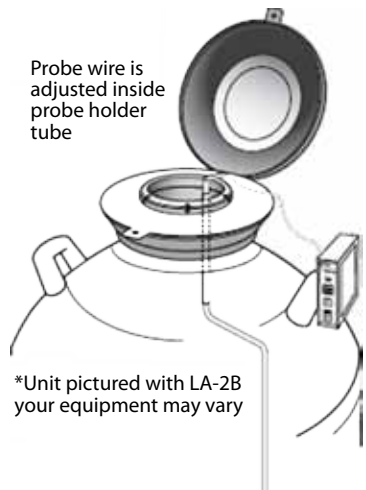

- FILL INSTRUCTIONS -

BAT-1B USERS ONLY: The probe sensitivity is pre-set at the factory. To change or adjust the sensitivity follow these steps: 1) Submerge the probe in liquid nitrogen for five minutes; 2) Turn the adjustment screw counter-clockwise until the alarm sounds; 3) Finally, turn the screw slowly clockwise just until the alarm stops. The probe is now properly adjusted for use.

**FIGURE B.
PROBE WIRE
CONNECTOR LOCATION**

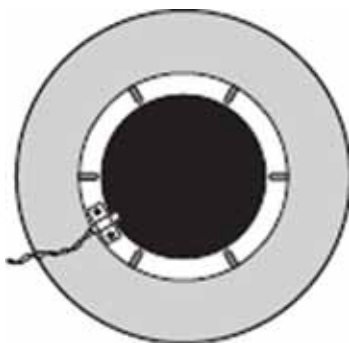

- FILL INSTRUCTIONS -

Follow these steps for filling your Vapor Shipper with liquid nitrogen:

1. Using the proper equipment as shown in the diagram, connect all the fill hardware to the supply tank.
2. User should dress in the appropriate safety gear.
3. Place Phase Separator into neck opening and hold in place while opening supply valve with free hand.

CAUTION:

Always closely follow the instructions on the containers and accessories when transferring liquid nitrogen. See the safety section of this manual on page 1 & 2 for important information on the dangers of proper first aid for liquid nitrogen accidents.

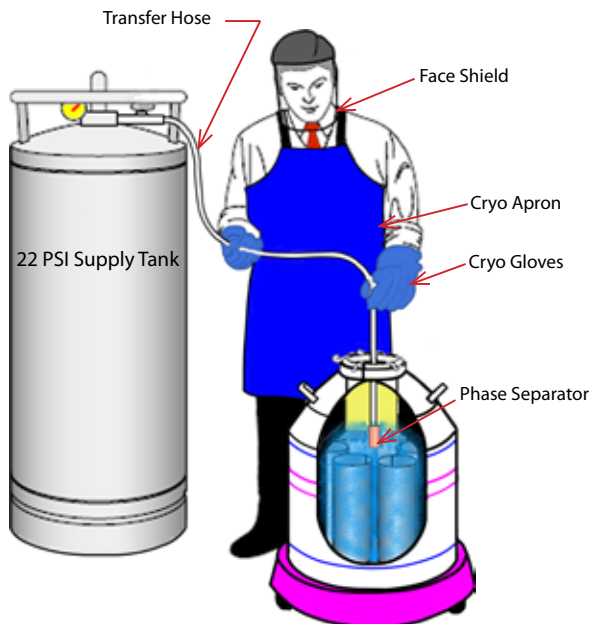

- UNIT PARAMETERS BY MODEL -

Use this section to become familiar with capacities, dimensions and normal liquid nitrogen use of your specific model. Units listed are the most common but do not represent all available models. Consult our factory for further information on models not listed.

MODEL	2002 Classic	4002 Classic	6002 Classic
Storage Capacities			
Number of Racks	4	4	6
Boxes per rack	5	10	10
Total vial capacity	2000	4000	6000
Liquid Nitrogen Usage & Capacities			
Liquid Nitrogen capacity (liters)	61	121	175
Static evaporation rate (liters/day)	0.85	0.99	0.99
Working volume (liters)	51	111	165
Normal working days	38	70	104
Dimensions			
Neck Opening (in/mm)	8.5 (216)	8.5 (216)	8.5 (216)
Overall Height (in/mm)	30.75 (781)	40.5 (1029)	40.5 (1029)
Outside Diameter (in/mm)	22 (559)	22 (559)	26 (665)

- Electronic Specifications -

Use this section to become familiar with the electronic specifications of your low level alarm.

LA-2B	BAT-1B
<p>Power requirements: 120/220 Volts AC / 24 Volts DC internal</p> <p>Remote contact type: Normally Open / Normally Closed</p> <p>Remote contact rating: 10 amp - 120 Volts AC / 6 amp - 220 Volts AC</p>	<p>Power requirements: One 9-Volt transistor radio battery</p>

- CRYOSYSTEM CLASSIC ASSEMBLY AND PARTS LIST -

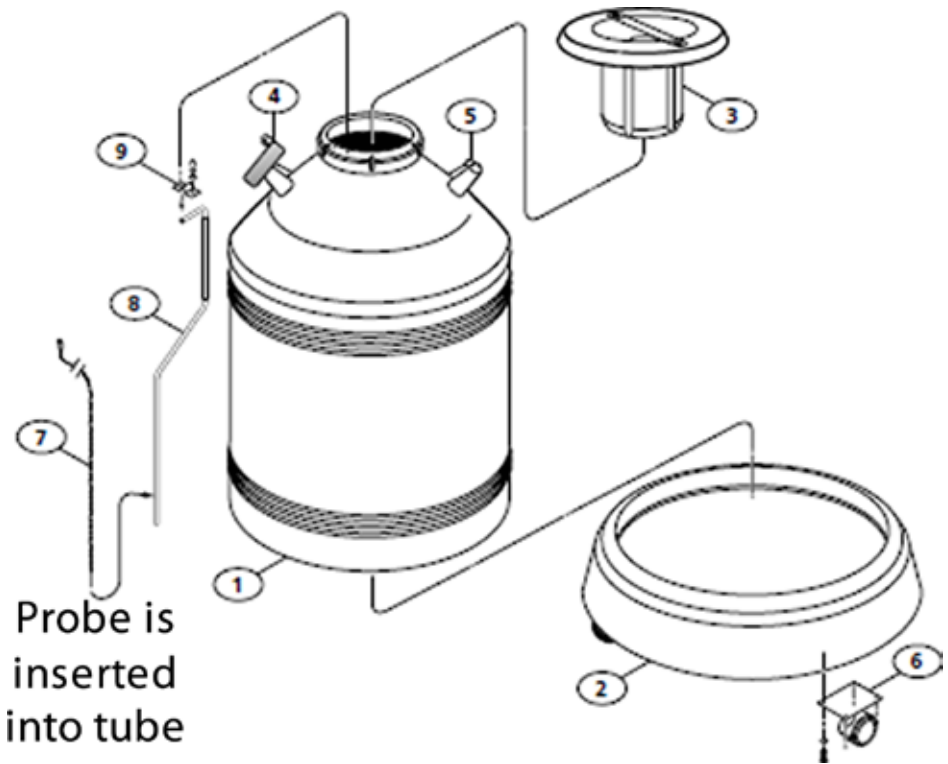

- | | | |
|------------------------|--------------|-------------|
| 1. Cryosystem Dewars | | |
| - Series 2002 | -#CB202-T | |
| - Series 4002 | -#CB402-T | |
| - Series 6002 | -#CB602-T | |
| 2. Roller Base | | |
| - Series 2002 | -#CB202-RB | |
| - Series 4002 & 6002 | -#CB4602-RB | |
| 3. Cryosystem Lids | | |
| Cryo-LA | -#2462-LAL | |
| Cryo-BAT or no alarm | -#2462-BATL | |
| 4. Alarm Control Panel | | |
| LA-2B | -#2460-LAP-T | |
| BAT-1B | -#2460-BATP | |
| No Alarm | -#2460-NAP | |
| 5. Lid Mount - All | | -#2462-LM |
| 6. Castor Wheel - All | | -#2462-CW |
| 7. Sensor Probe - All | | -#2462-SP |
| 8. Probe Holder Mount | | |
| -Series 2002 | | -#CB202-PHT |
| -Series 4002 | | -#CB402-PHT |
| 9. Probe Holder Clamp | | |
| All | | -#2462-PHC |



"T" Valve



Roller Base



Cryo Gloves



LN₂ Level Stick



"Y" Connector



Phase Separator



Canes and Straws



LN₂ Transfer Hose



Low Level
Alarm Multiplex

- TROUBLESHOOTING -

LA-2B		
CONDITION	CAUSE	SOLUTION
<ul style="list-style-type: none"> ◆ Alarm light flashes 	<ul style="list-style-type: none"> ◆ Alarm condition is present ◆ Sensor plug is disconnected ◆ Sensor is shorted 	<ul style="list-style-type: none"> ◆ Correct the low liquid level, or adjust the sensor to the proper level (see page 6) ◆ Connect sensor plug properly ◆ Locate and correct short
<ul style="list-style-type: none"> ◆ Alarm light flashes but no audible alarm heard 	<ul style="list-style-type: none"> ◆ Audible alarm is muted 	<ul style="list-style-type: none"> ◆ Push MUTE switch
<ul style="list-style-type: none"> ◆ No lights 	<ul style="list-style-type: none"> ◆ No power to controller ◆ AC power supply is not plugged in ◆ Power adaptor plug not plugged into "24V DC" socket on unit back panel 	<ul style="list-style-type: none"> ◆ Check for live power source ◆ Plug AC adaptor into a wall socket ◆ Plug power source properly into back panel using the diagram on page 3

- TROUBLESHOOTING -

BAT-1B		
CONDITION	CAUSE	SOLUTION
<ul style="list-style-type: none"> ◆ Red alarm light and audible alarm are present 	<ul style="list-style-type: none"> ◆ Alarm condition is present ◆ Sensor plug is disconnected ◆ Sensor is shorted ◆ Sensitivity control needs to be adjusted 	<ul style="list-style-type: none"> ◆ Correct the low liquid level, or adjust the sensor to the proper level (see page 6) ◆ Connect sensor plug properly ◆ Locate and correct short ◆ If liquid level does not warrant an alarm, turn sensitivity adjustment screw clockwise just until alarm stops (see page 7)
<ul style="list-style-type: none"> ◆ Alarm light flashes and audible alarm sounds intermittently 	<ul style="list-style-type: none"> ◆ Battery is losing power 	<ul style="list-style-type: none"> ◆ Replace with fresh battery using the diagrams on page 4
<ul style="list-style-type: none"> ◆ No lights 	<ul style="list-style-type: none"> ◆ ON/OFF switch in OFF position ◆ Defective or old battery 	<ul style="list-style-type: none"> ◆ Move POWER switch into the on position ◆ Replace with fresh battery using the diagrams on page 4

AVAILABLE FROM CBS

Liquid Nitrogen Equipment Including:

Freezers & Dewars

Controlled Rate Freezing Systems

Freezer Racks and Boxes

Transfer Lines

Solenoid Valves

Liquid Level & Temperature Alarms

Liquid Level & Temperature Controls

Temperature Recorders / Monitors

Cryogenic Accessories



**Custom
BioGenic
Systems**

**150 Shafer Drive
Romeo, Michigan 48065 U.S.A.**

CSC.TM0609

Revision: B

©2005 Custom BioGenic Systems

All designs and materials contained herein are protected under Federal copy right law. Unauthorized distribution or use will be subject to prosecution to the fullest extent of the law.